

3 | Fernbedienung anlernen/ teach remote control

Siehe Q-Fernbedienungsanleitung
See Q-remote control manual

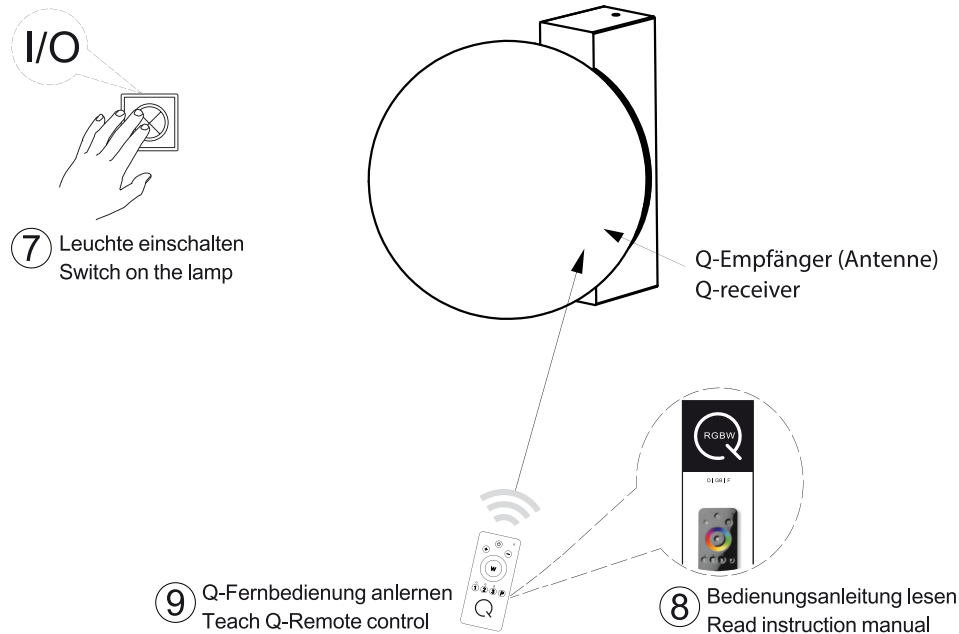

⚠ Reset

Rückstellen der Leuchte auf Werkseinstellung
Reset the lamp, factory new

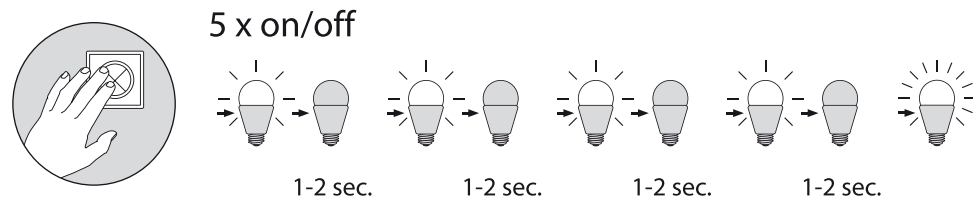

Das Gerät erfüllt die grundlegenden Anforderungen der Richtlinie 2014/53/EU (Radio Equipment Directive) des Europäischen Parlaments und des Rates der europäischen Union vom 16.04.2014 über Funkanlagen und die gegenseitige Anerkennung ihrer Konformität.
Die vollständige Konformitätserklärung kann bei der unten angegebenen Adresse angefordert werden.
Bitte geben Sie bei technischen Fragen die Chargennummer (xxxxx-xx-xx-xxxxx-xxx) an. Diese finden Sie auf dem Typenschild der Q-Leuchte.

This device fulfils the fundamental requirements of Directive 2014/53/EU (Radio Equipment Directive) of the European Parliament and of the Council of the European Union dated 16.04.2014 on items of radio equipment and the mutual recognition of their conformity.
The full declaration of conformity can be requested from the address given below.
When raising any technical questions, please cite the batch number (xxxxx-xx-xx-xxxxx-xxx). You will find it on the Q light fittings type plate.

Paul Neuhaus

Paul Neuhaus GmbH
Olakenweg 36 · D-59457 Werl







Telefon: +49 (0) 29 22-97 21-0
Telefax: +49 (0) 29 22-97 21-9120
E-mail: info@neuhaus-group.de
www.neuhaus-group.de

Q[®]
**SMART
HOME
LIGHTS**

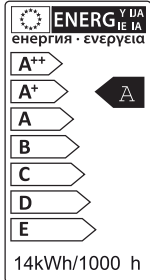
D | Montageanleitung GB | Fitting instructions

831262

230V / 50 Hz
10W LED-Board
nicht wechselbar / not changeable

LED	10W	
	900 Lumen	
t	14W	
	500 Lumen	
T _k	25.000h	
	3.000 /RGBW	
	15.000 x	
	<0.5s	
	Dimmable with rrc	



AAA, 1,5V

Inkl. Funkfernbedienung
Incl. radio remote control



1 | Montage / fitting

Als Wandleuchten
As wall light

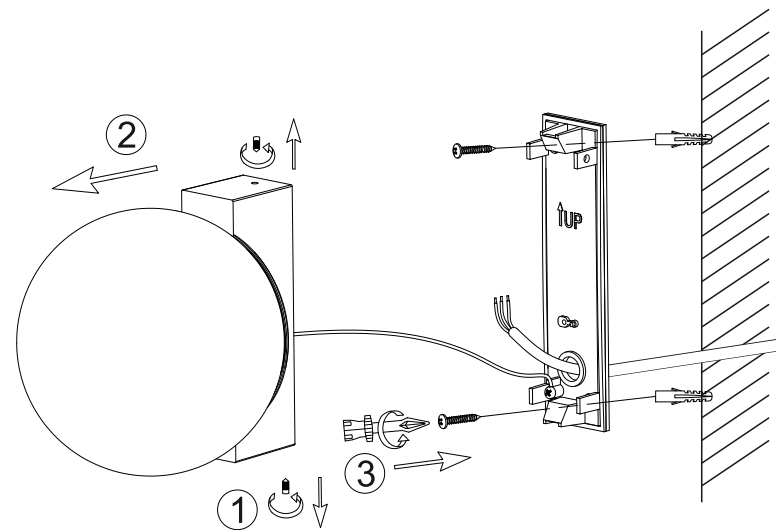

2 | Elektrischer Anschluss / electrical connection

230 Volt / 50Hz-Anschluss
230 Voltage / 50Hz connection

