



SMART
HOME
LIGHTS

D | Montageanleitung • GB | Fitting instructions

832436

220-240V~50/60Hz

1x 10W LED-Board

nicht wechselbar / not changeable



t

T_K



10 W

1.250 Lm

12 W

640 Lm

LED-Board

25.000 h

2.700-5.000 K/RGB

15.000 x

< 0,5s

dimmable with rrc

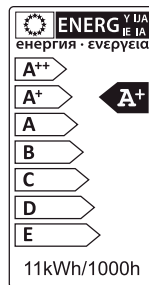

AAA, 1,5V

Inkl. Funkfernbedienung
Incl. radio remote control



1 x A

2 x B

1 x C

1 x D



1 | Montage / fitting

a) Als Tischleuchte
As table lamp

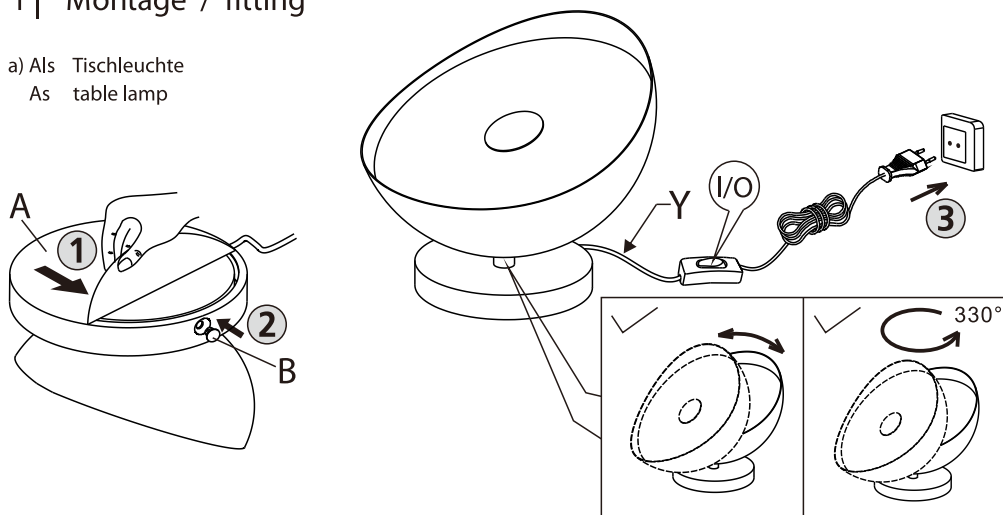

b) Als Deckenleuchte
As ceiling lamp

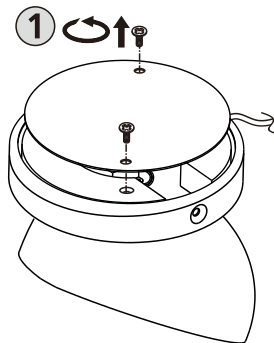

2 | Elektrischer Anschluss / electrical connection

220-240 Volt~50/60 Hz-Anschluss

220-240 voltage~50/60 Hz connection

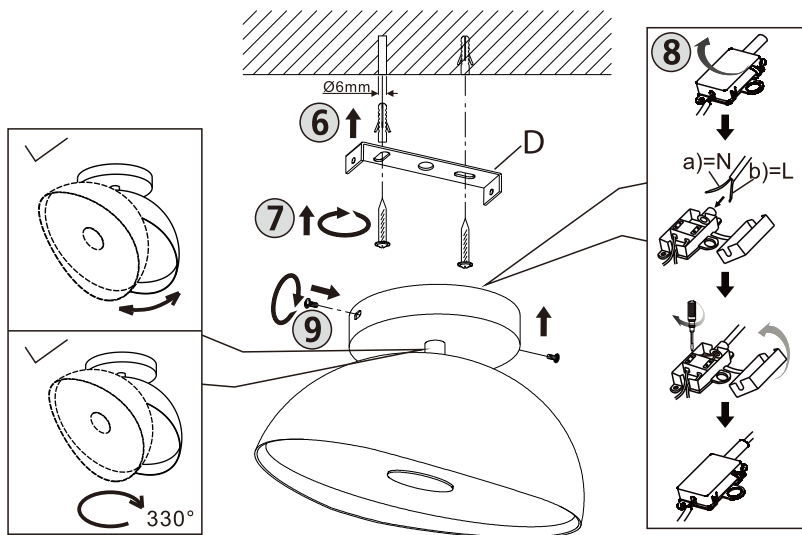
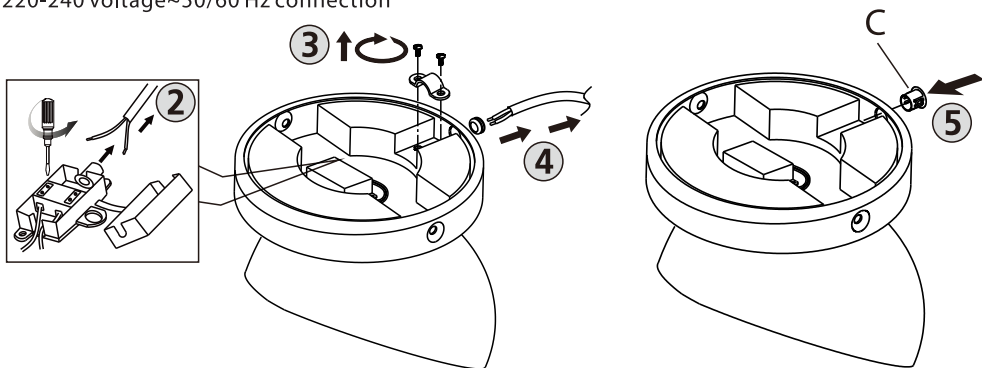

3 | Fernbedienung anlernen / teach remote control

Siehe Q-Fernbedienungsanleitung
See Q-remote control manual

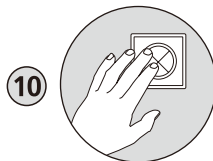

Leuchte einschalten
Switch on the lamp

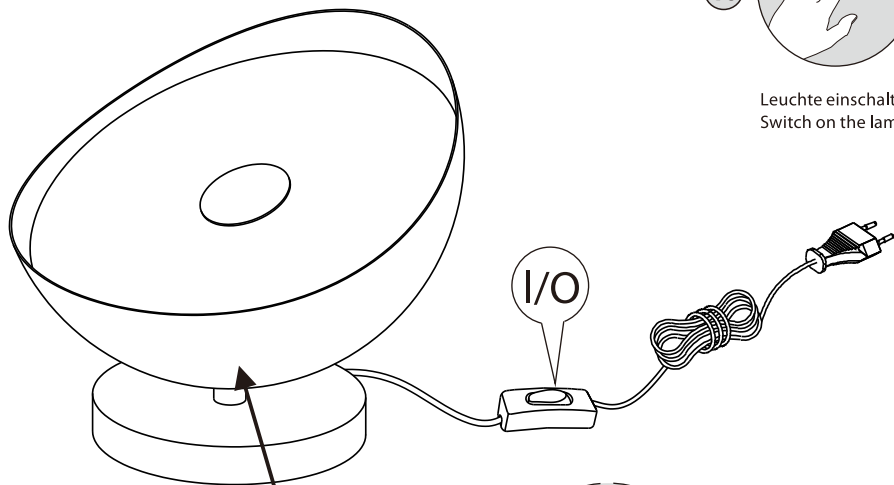

12

Q-Fernbedienung
anlernen
Teach Q-remote
control



11

Bedienungsanleitung
lesen
Read instruction
manual



Reset

Rückstellen der Leuchte auf Werkseinstellung
Reset the lamp, factory new

5 x on/off

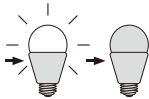
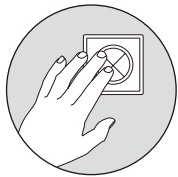

1-2 sec.

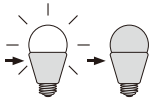

1-2 sec.

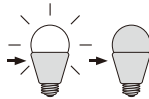

1-2 sec.

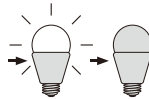

1-2 sec.



Das Gerät erfüllt die grundlegenden Anforderungen der Richtlinie 2014/53/EU (Radio Equipment Directive) des Europäischen Parlaments und des Rates der europäischen Union vom 16.04.2014 über Funkanlagen.

Die vollständige Konformitätserklärung kann bei der unten stehenden Internet-Adresse aufgerufen werden.

This device fulfils the fundamental requirements of Directive 2014/53/EU (Radio Equipment Directive) of the European Parliament and of the Council of the European Union dated 16.04.2014 on items of radio equipment.

The full declaration of conformity can be accessed at the Internet-address given below.

Paul Neuhaus

Paul Neuhaus GmbH
Olakenweg 36 · D-59457 Werl

Telefon: +49 (0) 2922-9721-0
Telefax: +49 (0) 2922-9721-9120
E-Mail: kundenservice@neuhaus-group.de
<https://scm.paul-neuhaus.de/public/conformity/>